

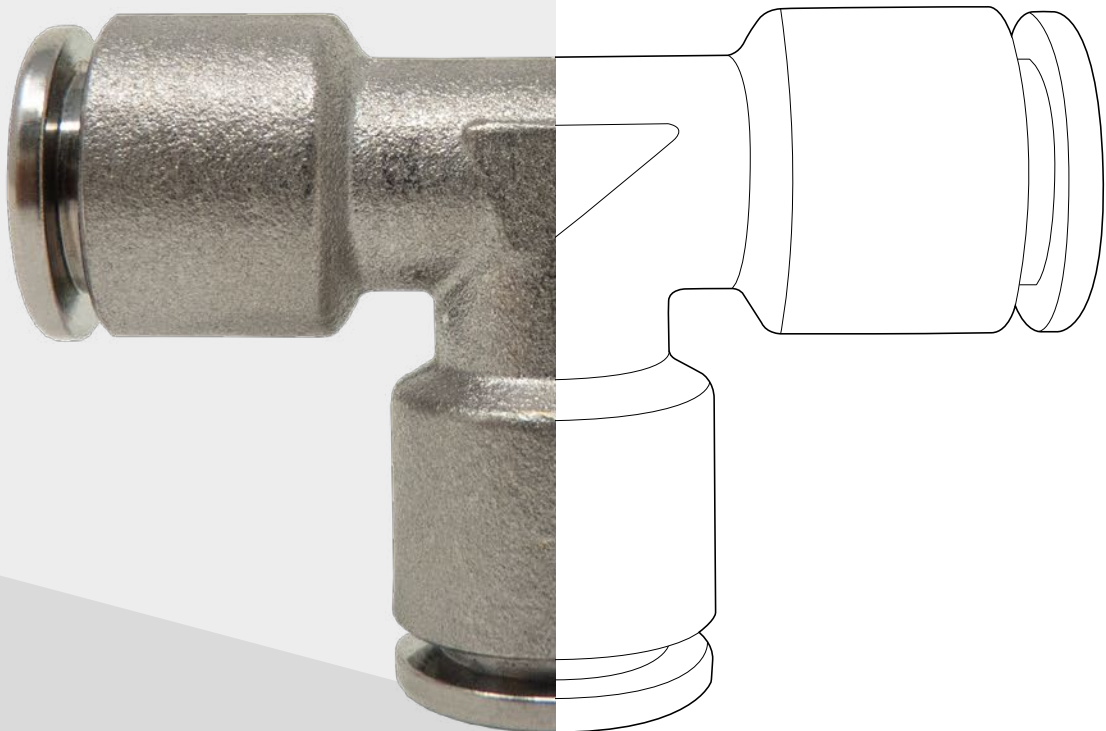

# FOOD GRADE HFR SERIES

MADE IN ITALY







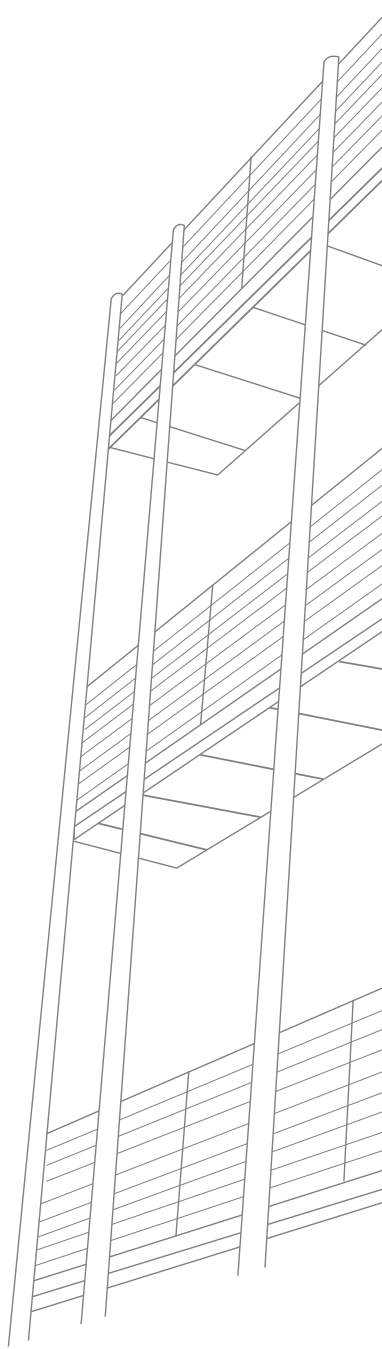

 **TierreGroup**®

 **TierreFittings**®

 **F-Line.PRO**

 **NET.Fit**®

 **INOX.Fit**®





# FOOD GRADE HFR SERIES



## PLUS

**TEA+ SURFACE TREATMENT ABLE TO GUARANTEE HIGH RESISTANCE TO CORROSION AND CHEMICALS**

**RELIABILITY** and **HIGH MECHANICAL EFFICIENCY** as key features for high performances

**COMPLETE RANGE** for any application

Suitable for **FOOD & BEVERAGE AND COFFEE MACHINES**

**TAILOR MADE PRODUCTS ON SPECIFIC CUSTOMERS NEEDS**

M A D E I N I T A L Y





p. 8 / **HFR-C-G**



p. 8 / **HFR-O-C-M**



p. 8 / **HFR-C-F-G**



p. 9 / **HFR-M-M**

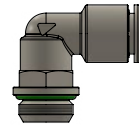

p. 9 / **HFR-L-G**

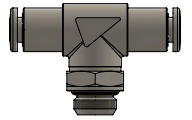

p. 9 / **HFR-T-G**

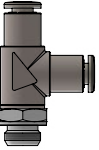

p. 10 / **HFR-S-T-G**



p. 10 / **HFR-A-G**

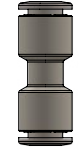

p. 10 / **HFR-U-C**

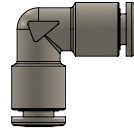

p. 11 / **HFR-L**

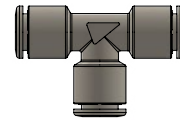

p. 11 / **HFR-T**

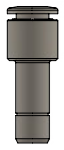

p. 11 / **HFR-G-J**





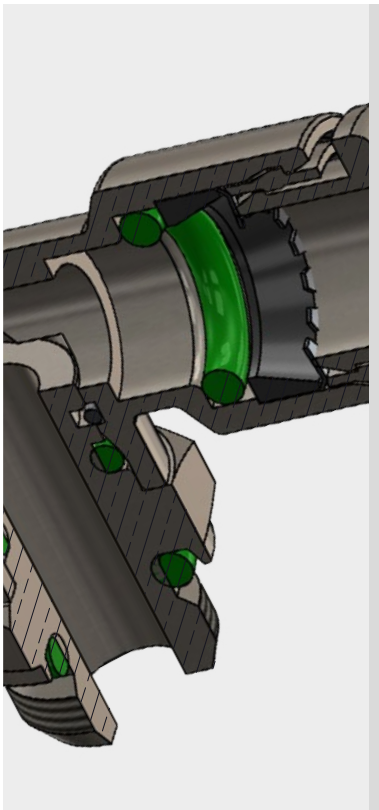

-20°C ÷ 150°C



Working Pressure:

20 Bar

Negative Pressure:

- 0,95 Bar (- 99 Kpa)



Compressed air, vacuum,  
water and fluids suitable with  
the construction materials



- Parallel gas BSPP ISO 228

G1/8" - G1/2"

- Metric ISO 262

M5 and M7



Polyamide PA, Polyethylene

PE, FEP, and PTFE

Body: TEA+ plated brass

Collet: TEA+ plated brass

Collar: PVDF-UHM FDA compliant

Lock claw: Stainless steel AISI 301

Back ring: PVDF-UHM FDA compliant

O'ring: FKM NSF/ANSI 61 certified  
and FDA compliant

Seal: FKM NSF/ANSI 61 certified  
and FDA compliant

Retaining ring for swivel system:  
Stainless steel AISI 302



NSF/ANSI 169

COMPONENT



Food contact materials  
EC 1935/2004



ICIM certified product  
food contact materials



SILICONE FREE



Products in compliance with  
the directive 1907/2006

RoHS3

Products in compliance with  
the directive EU 2015/863



TEA+

**HIGHLY CORROSION RESISTANT** in strong acidic or alkaline environments:

- thicknesses of 2 - 4 µm withstand
- ASS 96h and CASS 48h salt spray tests

**EN 16058** rig test ( 26 weeks)

**NSF 61** section 8- pH5 Commercial hot (82°C) for taps, sanitary fittings, HVAC

**EN 16889** for professional coffee machines and other "food zone" devices.

## CONSTRUCTION DETAILS

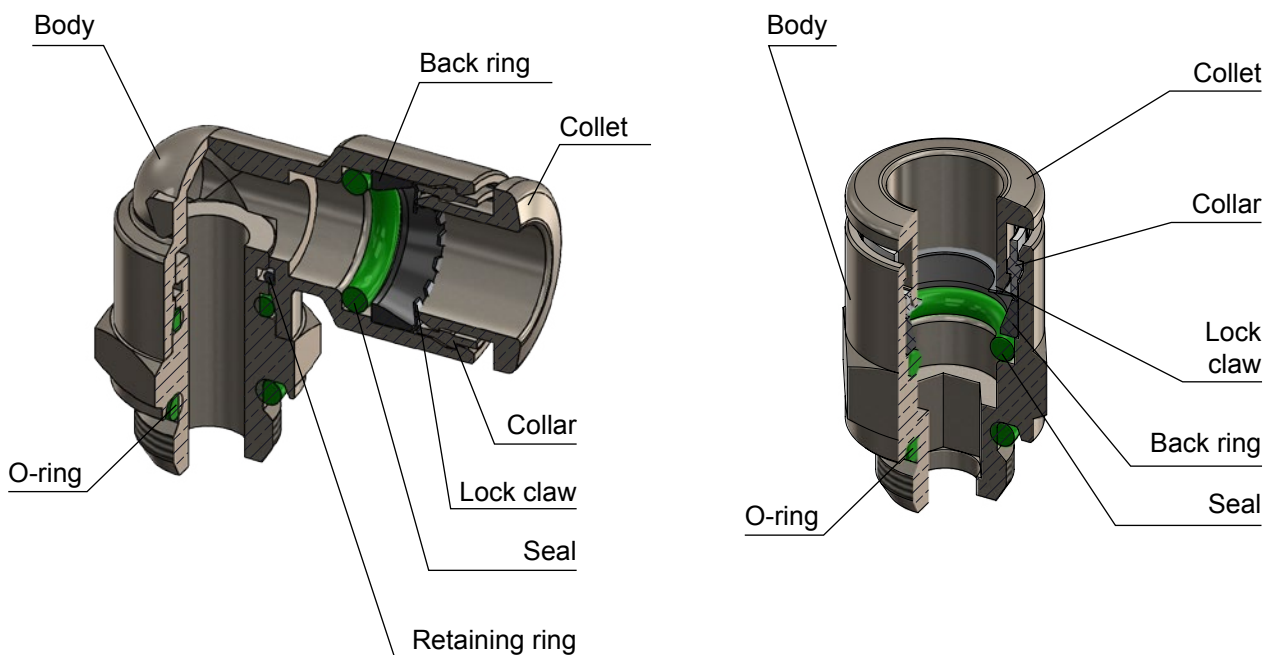



### INSERTION OF THE TUBE INTO THE FITTING

- Make sure the tube is fully inserted into the fitting.
- To insert the tube into the fitting cut the tube off square (90°), insert tube up to the fitting end stop, and pull back gently to make sure it is correctly connected.
- If there is any damage or scratches on the tube surface the tube is an oval shape, air leakage and tube release may occur. Check the tube condition carefully.
- The OD of polyurethane tube expands when pressure is applied. Reinsertion into the fitting may not always be possible. Check the OD of the tube and renew it the expansion is out of tolerance.

### DISCONNECTION OF THE TUBE FROM THE FITTING

- Make sure the pressure in the system is zero before releasing the tube from the fitting.
- To release the tube, press the release sleeve towards the fitting with one hand (1) and pull the tube away from the fitting with the other hand (2).
- Always remove the section of tube previously inserted into the fitting before reinserting the tube by cutting back the tube. Always use the correct tube cutter in order to cut the tube square and free of damage.

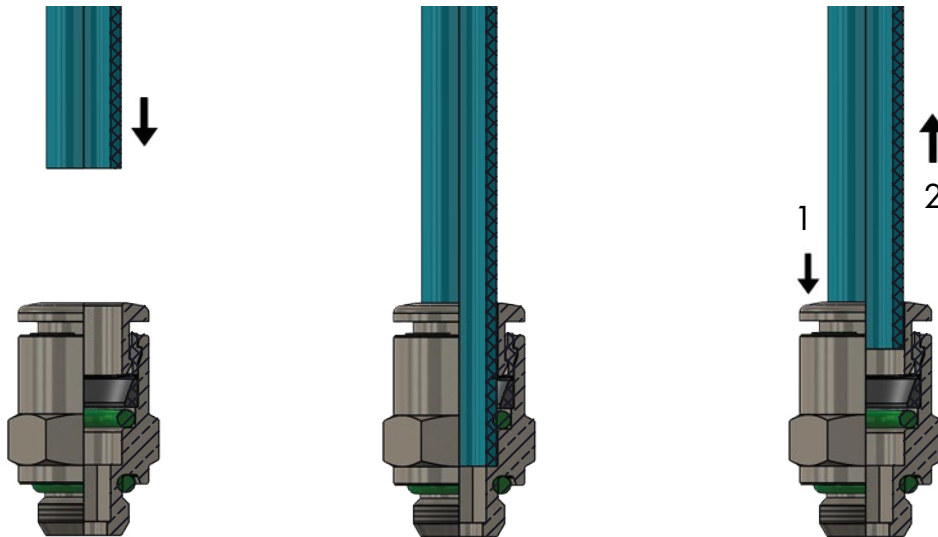

#### TUBE TOLERANCES

Ø TUBE (mm)	4	6	8	10	12
TOLERANCE (mm)	± 0,1	± 0,1	± 0,1	± 0,15	± 0,15

#### TUBE INSERTION DEPTH

Ø TUBE (mm)	4	6	8	10	12
TUBE INSERTION LENGTH (mm)	14	15,5	17,5	19	21

#### TIGHTENING TORQUE

PARALLEL GAS BSPP ISO 228 & METRIC ISO 262

THREAD	M5x0,8	M7x1	1/8"	1/4"	3/8"	1/2"
Nm	0,8	0,8	1,2	1,5	2,5	3,5



HFRC-G



Male connector BSPP & metric thread

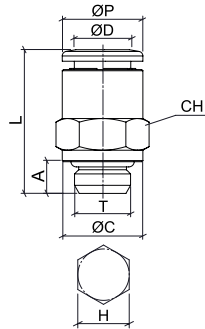
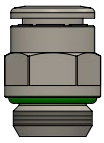

CODE	ØD	T	ØP	ØC	A	L	CH	H
HFRC04M5	4	M5x0,8	10	7	4	19,0	9	2,5
HFRC04G01		G 1/8"	10	14	5,5	18,0	10	3
HFRC04G02		G 1/4"	10	16	6,5	18,0	10	3
HFRC06M5	6	M5x0,8	12	7	4	21,0	11	2,5
HFRC06G01		G 1/8"	12	14	5,5	19,5	12	4
HFRC06G02		G 1/4"	12	16	6,5	19,5	12	4
HFRC08G01	8	G 1/8"	14	14	5,5	24,5	14	5
HFRC08G02		G 1/4"	14	16	6,5	21,5	14	6
HFRC08G03		G 3/8"	14	20	7,5	21,5	14	6
HFRC10G02	10	G 1/4"	16	16	6,5	27,5	16	7
HFRC10G03		G 3/8"	16	20	7,5	25,0	16	8
HFRC12G02	12	G 1/4"	19	16	6,5	30,0	19	7
HFRC12G03		G 3/8"	19	22	7,5	29,5	19	10
HFRC12G04		G 1/2"	19	25	9	28,0	19	10

HFROC



Male connector round body metric thread

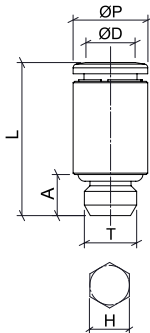

CODE	ØD	T	ØP	A	L	H
HFROC04M7	4	M7x1	10	6	20,5	2,5
HFROC06M7C	6	M7x1	10	5,5	20,5	4

HFRCF-G



Female connector BSPP thread

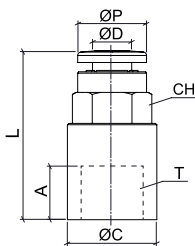

CODE	ØD	T	ØP	ØC	A	L	CH
HFRCF04G01	4	G 1/8"	10	13	7,5	24,5	13
HFRCF04G02		G 1/4"	10	16	11	27,0	10
HFRCF06G01	6	G 1/8"	12	13	7,5	26,0	12
HFRCF06G02		G 1/4"	12	16	11	29,0	12
HFRCF08G01	8	G 1/8"	14	13	7,5	27,0	14
HFRCF08G02		G 1/4"	14	16	11	30,0	14



HFRMM



Bulkhead connector

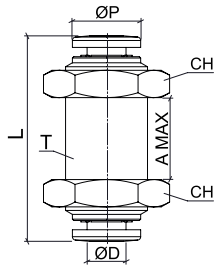
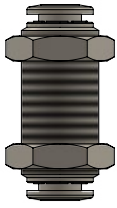

CODE	ØD	T	ØP	L	A MAX	CH
HFRMM04	4	M12x1	10	34,0	15	16
HFRMM06	6	M14x1	12	32,0	12	17
HFRMM08	8	M16x1	14	36,5	16	19
HFRMM10	10	M20x1	16	43,0	19	24
HFRMM12	12	M22x1,5	19	44,0	20	25

HFRL-G



Swivel male elbow BSPP & metric

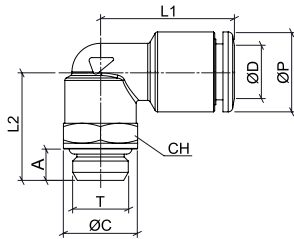
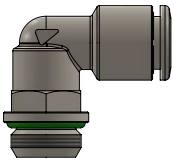

CODE	ØD	T	ØP	ØC	A	L1	L2	CH
HFRLO4M5	4	M5x0,8	10	7	4	18,0	15,0	8
HFRLO4G01		G 1/8"	10	13	5,5	19,5	19,0	13
HFRLO4G02		G 1/4"	10	16	6,5	19,5	21,5	13
HFRLO6M5	6	M5x0,8	12	7	4	19,5	16,0	8
HFRLO6G01		G 1/8"	12	13	5,5	21,0	19,0	13
HFRLO6G02		G 1/4"	12	16	6,5	21,0	21,5	13
HFRLO8G01	8	G 1/8"	14	13	5,5	23,0	19,0	13
HFRLO8G02		G 1/4"	14	16	6,5	23,0	21,5	13
HFRLO8G03		G 3/8"	14	20	7,5	23,0	23,0	13
HFRLO10G02	10	G 1/4"	16	16	6,5	26,0	23,0	16
HFRLO10G03		G 3/8"	16	20	7,5	26,0	26,0	16
HFRLO12G02	12	G 1/4"	19	16	6,5	31,0	25,5	20
HFRLO12G03		G 3/8"	19	20	7,5	31,0	26,5	20
HFRLO12G04		G 1/2"	19	25	9	31,0	29,0	20

HFRT-G



Swivel male tee BSPP thread

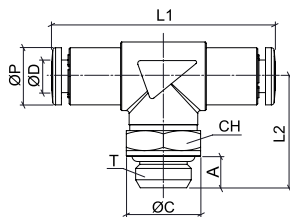
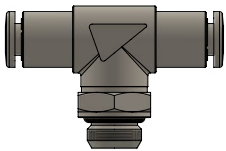

CODE	ØD	T	ØP	A	L1	L2	CH
HFRT04G01	4	G 1/8"	10	5,5	39,0	19,5	13
HFRT06G01	6	G 1/8"	12	5,5	42,0	19,5	13
HFRT06G02		G 1/4"	12	6,5	42,0	22,0	13
HFRT08G01	8	G 1/8"	14	5,5	46,5	19,5	13
HFRT08G02		G 1/4"	14	6,5	46,5	22,0	13



HFRST-G



Swivel male lateral tee BSPP thread

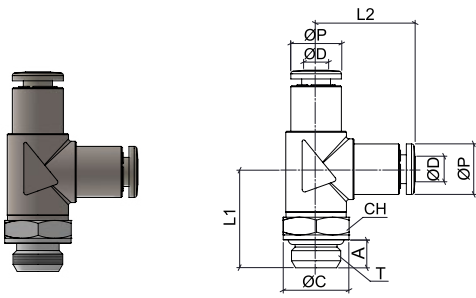

CODE	ØD	T	ØP	ØC	A	L1	L2	CH
HFRST04G01	4	G 1/8"	10	13	5,5	19,5	19,5	13

HFRA-G



Stem adapter BSPP thread

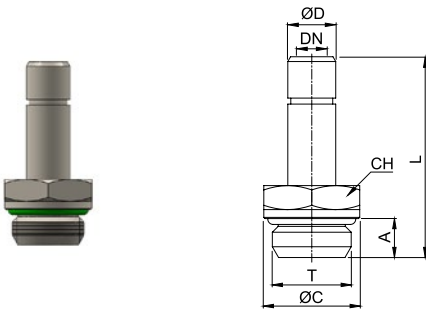

CODE	ØD	T	ØC	A	L	DN	CH
HFRA04G01	4	G 1/8"	13	5,5	28,0	2,0	13
HFRA06G01	6	G 1/8"	13	5,5	29,0	4,0	13
HFRA06G02		G 1/4"	16	6,5	30,5	4,0	13
HFRA08G01	8	G 1/8"	13	5,5	30,0	6,0	13
HFRA08G02		G 1/4"	16	6,5	32,0	6,0	13
HFRA10G01	10	G 1/8"	13	5,5	35,0	6,0	13
HFRA10G02		G 1/4"	16	6,5	36,5	8,0	13
HFRA12G02	12	G 1/4"	16	6,5	37,5	8,0	13

HFRUC



Union connector

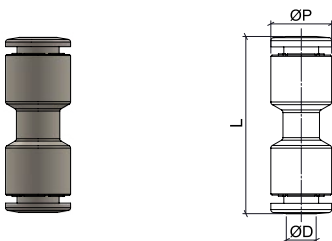

CODE	ØD	ØP	L
HFRUC04	4	10	29,0
HFRUC06	6	12	32,0
HFRUC08	8	14	35,5
HFRUC10	10	16	39,5
HFRUC12	12	19	44,0





HFRUL



Union elbow

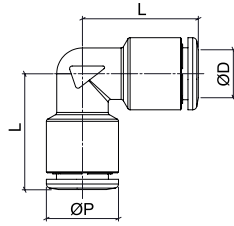
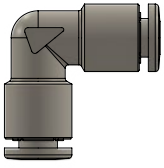

CODE	ØD	ØP	L
HFRUL04	4	10	18,0
HFRUL06	6	12	19,5
HFRUL08	8	14	22,5
HFRUL10	10	16	25,5
HFRUL12	12	19	29,0

HFRUT



Union tee

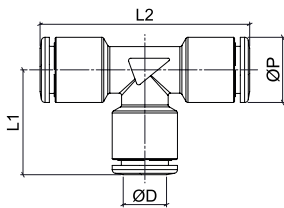
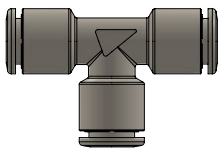

CODE	ØD	ØP	L1	L2
HFRUT04	4	10	18,0	36,0
HFRUT06	6	12	19,5	39,0
HFRUT08	8	14	22,5	45,0
HFRUT10	10	16	25,5	51,0
HFRUT12	12	19	29,0	58,0

HFRGJ



Stem reduction

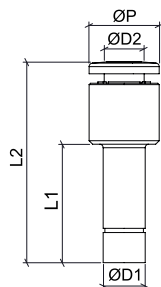

CODE	ØD1	ØD2	ØP	L1	L2
HFRGJ0604	6	4	10	170	28,5
HFRGJ0806	8	6	12	19,5	34,5
HFRGJ1008	10	8	14	24,0	37,5
HFRGJ1210	12	10	16	25,0	40,0



**NSF CERTIFICATION FOR TIERRE GROUP S.P.A.**

# NSF International

789 N. Dixboro Road, Ann Arbor, MI 48105 USA

RECOGNIZES

**Tierre Group S.p.A.**  
Italy

AS COMPLYING WITH NSF/ANSI 169 AND ALL APPLICABLE REQUIREMENTS.  
PRODUCTS APPEARING IN THE NSF OFFICIAL LISTING ARE  
AUTHORIZED TO BEAR THE NSF MARK.



Certification Program  
Accredited by the  
American National  
Standards Institute



Certification Program  
Accredited by the  
Standards Council  
of Canada

This certificate is the property of NSF International and must be returned upon request. This certificate remains valid as long as this client has products in NSF's Official Listings for the referenced standards. For the most current and complete Listing information, please access NSF's website ([www.nsf.org](http://www.nsf.org)).

July 10, 2019  
Certificate# C0484626 - 01

A handwritten signature in black ink, appearing to read "S. Krol", written over a horizontal line.

Sarah Krol  
Global Managing Director, Food Safety Product Certification



**FOOD CONTACT MATERIALS DECLARATION - EC 1935/2004\***

\* Full certification available on our website ([www.tierrefittings.com](http://www.tierrefittings.com)) or on request.



Tierre Group S.p.a.  
 Headquarter: Via Dell'Industria 18 – 20032 Cormano (MI) – Italy  
 Warehouse: Via Dell'Artigianato 2 – 20032 Cormano (MI) – Italy  
 Production: Via Marco Biagi 1 – 25045 Castegnato (BS) – Italy  
 C.F. e P.IVA IT 12437570158 – Capital €120.000,00 i.v.  
 REA MI-1558390



Phone. +39 02 663088.1 – Fax +39 02 66304172  
[www.tierregroup.com](http://www.tierregroup.com) – [info@tierregroup.com](mailto:info@tierregroup.com)

**DECLARATION OF CONFORMITY**



**Materials And Articles Intended To Come Into Contact With Food**

**TIERRE GROUP S.p.a.**

**DECLARES**

That the items related to the following product range:

***FOOD GRADE SERIES HFR - Brass push-in fittings with TEA<sup>+</sup> surface treatment***

***XVR INOX AISI 316 L SERIES – AISI 316 L stainless steel push-in fittings***

**ARE IN COMPLIANCE WITH**

**EC 1935/2004** regulation of the European Parliament and of the Council dated 27<sup>th</sup> October 2004 on materials and articles intended to come into contact with food and abrogating the Directives 80/590/EEC and 89/109/EEC

Commission Regulation **EC 2023/2006** dated 22<sup>nd</sup> December 2006 on good manufacturing practice for materials and articles intended to come into contact with food

The items of the above ranges have been produced with the following materials:

***FOOD GRADE SERIES HFR:***

UNI EN 12164 CW 614 L brass - UNI EN 12164 CW 617 L brass  
 Viton - EPDM (option)  
 TEA<sup>+</sup> surface treatment  
 AISI 302

***XVR INOX AISI 316 L:***

AISI 316 L  
 Viton - EPDM (option)  
 AISI 302



## ICIM CERTIFICATION PRODUCT - FOOD CONTACT MATERIALS - TIERRE GROUP S.P.A.

		
PRD N° 004 B Membro degli Accordi di Mutuo Riconoscimento EA, IAF e ILAC Signatory of EA, IAF and ILAC Mutual Recognition Agreements		
		
<b>Certificazione di Prodotto</b> <i>Product Certification</i>		
Certificato N. Certificate No.	<b>ICIM-MOC-009809-00</b>	
ALL'AZIENDA / TO THE FIRM		
<b>TIERRE GROUP S.P.A.</b>		
Via dell'Industria, 18 – 20032 Cormano (MI) Italia		
PER I SEGUENTI PRODOTTI / FOR THE FOLLOWING PRODUCTS		
<b>Raccordi ad innesto rapido in acciaio inox AISI 316L.</b> <b>Raccordi ad innesto rapido in ottone con trattamento T.E.A.</b> <b>AISI 316L stainless steel push-in fittings.</b> <b>Brass push-in fittings with T.E.A. plating</b>		
CON DENOMINAZIONE COMMERCIALE / WITH TRADE NAME/S		
Serie XVR INOX AISI 316L / XVR SERIES INOX AISI 316L Food grade serie HFR / Food grade HFR SERIES		
<small>(Utilizzo limitato ai fluidi per i quali sono previste prove con i simulanti A, C e D come definito dal DM n.338 del 22 luglio 1998, All. I, Cap. I)          (Use limited to fluids for which tests are provided for simulants A, C and D as defined by Ministerial Decree no. 388 of 22 July 1998, Annex I, Chap. I.)</small>		
CONFORMEMENTE AL DOCUMENTO NORMATIVO ICIM / IN COMPLIANCE WITH ICIM NORMATIVE DOCUMENT		
<b>0445CS</b>		
PRODOTTI E COMPONENTI A CONTATTO CON ALIMENTI SECONDO DISPOSIZIONI MOCA PRODUCTS AND COMPONENTS IN CONTACT WITH FOOD ACCORDING TO FCM REGULATIONS		
 <b>ICIM S.p.A.</b>		
PRIMA EMISSIONE FIRST ISSUE	EMISSIONE CORRENTE CURRENT ISSUE	DATA DI SCADENZA EXPIRING DATE
<b>13/02/2020</b>	<b>13/02/2020</b>	<b>12/02/2025</b>
<small>ICIM S.p.A. - Piazza Don Enrico Mapelli, 75 - 20099 Sesto San Giovanni (MI)</small>		

0546CM\_00\_IT





# NOTES



A series of horizontal lines for writing notes, spanning the width of the page.









**Tierre Group S.p.a.**

via dell'Industria, 18 - 20032 Cormano (MI)

Tel. +39 02 663088.1 - Fax +39 02 66304172

[www.tierregroup.com](http://www.tierregroup.com) - [info@tierregroup.com](mailto:info@tierregroup.com)

C.F. e P.IVA 12437570158

Cap. Soc. Euro 120.000,00 i.v. - REA MI-1558390

Food grade HFR Series catalogue - Ed. 1.0 - 08/20